

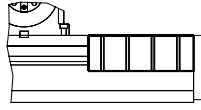

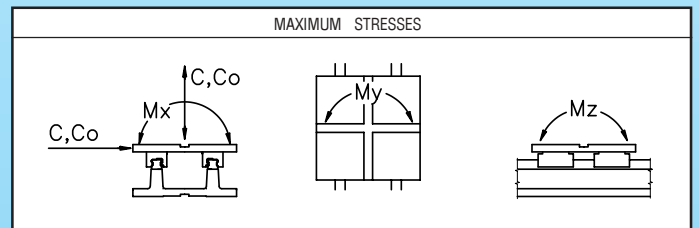

| SLIDE UNITS |          | STROKE       |
|-------------|----------|--------------|
| TYPE        | CODE     | mm (inch)    |
| S.TI.200    | 10315070 | 200 (7.87")  |
| S.TI.300    | 10315080 | 300 (11.81") |
| S.TI.400    | 10315090 | 400 (15.75") |

| ACCESSORIES  |                 |          |
|--|-----------------|----------|
| SLIDEWAY COVER   | STROKE          | CODE     |
|  | 200 mm (7.87")  | 28050044 |
|  | 300 mm (11.81") | 28050046 |
|  | 400 mm (15.75") | 28050048 |

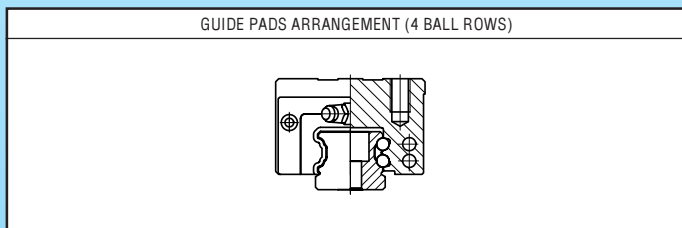
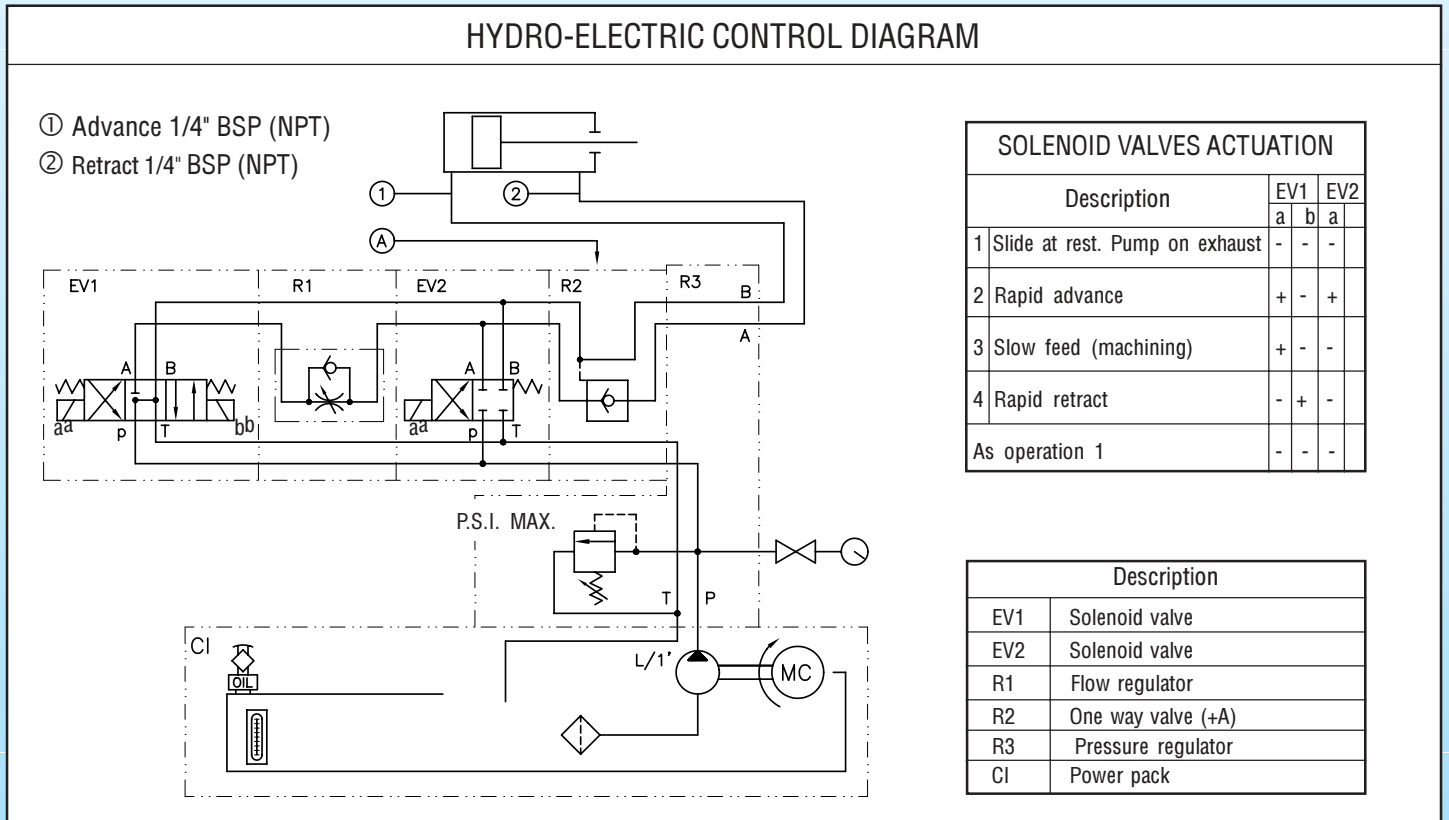

|  | TECHNICAL FEATURES |                           |  |   |               |                    |                        |                |                |                  |                  |                  |
|---|--------------------|---------------------------|--|---|---------------|--------------------|------------------------|----------------|----------------|------------------|------------------|------------------|
|   | TYPE OF THRUST     | TOTAL STROKE<br>mm (inch) | THRUST<br>N (lbs)<br>40 bar (580 P.S.i.) | CYLINDER<br>SECT AREA<br>cm <sup>2</sup> (inch <sup>2</sup> ) |               | WEIGHT<br>KG (lbs) | STANDARD COLOUR<br>RAL | LOAD CAPACITY  |                | STATIC MOMENT    |                  |                  |
|   |                    |                           |  | Advance   | Retract       |                    |                        | KN (lbs)       |                | Mx<br>Nm (ft.lb) | My<br>Nm (ft.lb) | Mz<br>Nm (ft.lb) |
|   |                    |                           |  |   |               |                    |                        | C<br>dynamic   | Co<br>static   |                  |                  |                  |
| S.TI.200  | 200<br>(7.87")     | 15500<br>(3418)           | 31.17<br>(4.83")                         | 21.13<br>(3.28")  | 92<br>(202.5) | 7035               | 110<br>(24255)         | 220<br>(48510) | 3800<br>(2802) | 4400<br>(3245)   | 4700<br>(3466)   |                  |
| S.TI.300  | 300<br>(11.81")    |                           |  |   |               |                    |                        |                |                |                  |                  |                  |
| S.TI.400  | 400<br>(15.75")    |                           |  |   |               |                    |                        |                |                |                  |                  |                  |